

NOTES :

1- MATERIAL:

-HOUSING: L C P FIBER GLASS FILLED
UL 94-V0 COLOR BLACK.

-MODULE : L C P FIBER GLASS FILLED
UL 94-V0 COLOR BLACK.

-TERMINAL: PHOSPHOR BRONZE .

PLATING:

POST PLATE 0.00127-0.00152/.000050-.000060 GOLD
IN CONTACT AREA.

0.00190/.000075 MIN PURE TIN IN TAIL AREA
BOTH OVER 0.00127/.000050 MIN NICKEL OVERALL.

2- JACK FOR MATING WITH FCC 68 PLUGS
90075 MOLEX SERIES.

3- PCB THICKNESS : 1.57 / .062

4- PRODUCT SPECIFICATION PS-95502-001

5- PACKAGING SPECIFICATION PK-95002

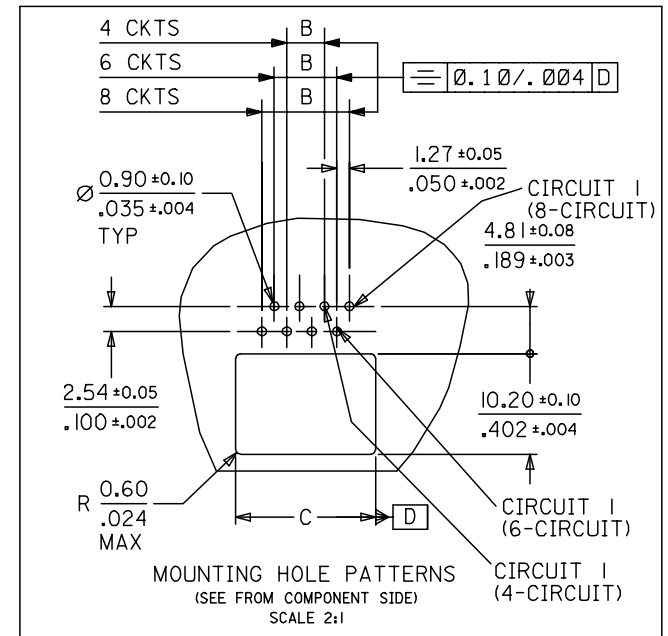

P/N	HOUSING SIZE	CKTS.	DIM.		
			A ±0.13	B $\begin{matrix} +0.05 \\ -0.10 \\ +0.002 \\ -0.004 \end{matrix}$	C $\begin{matrix} +0.08 \\ -0.003 \end{matrix}$
95502-2443	POS 4	4 CKTS	$\frac{11.50}{.453}$	$\frac{3.81}{.150}$	$\frac{10.20}{.402}$
95502-2643	POS 6	4 CKTS	$\frac{13.55}{.533}$	$\frac{3.81}{.150}$	$\frac{12.20}{.480}$
95502-2663	POS 6	6 CKTS	$\frac{13.55}{.533}$	$\frac{6.35}{.250}$	$\frac{12.20}{.480}$
95502-2883	POS 8	8 CKTS	$\frac{15.55}{.612}$	$\frac{8.89}{.350}$	$\frac{14.20}{.559}$

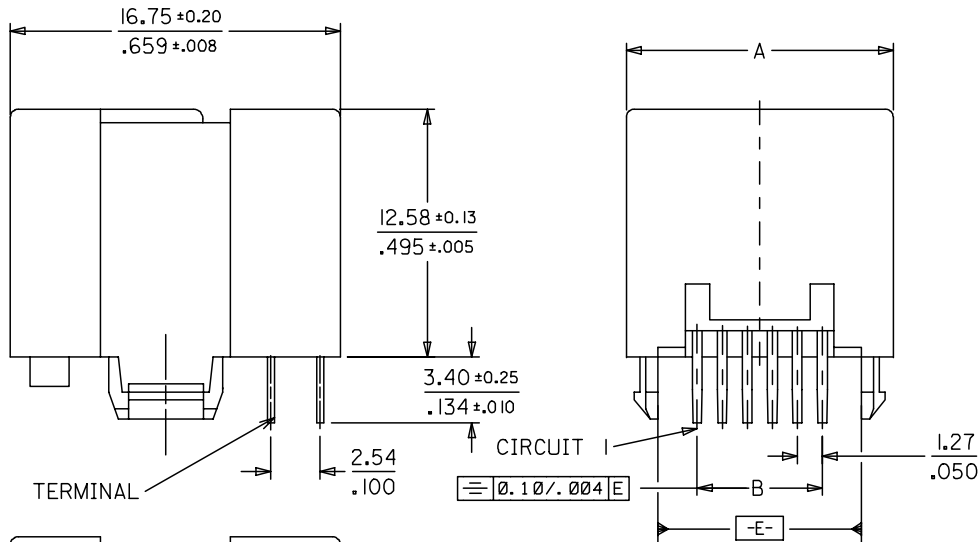

MODIFIED MATL.
EC NO: E2007-0611
DRWN:DBYRNES 2007/01/22
CHKD: 2007/01/22
APPR:EOMAHONY 2007/01/25

QUALITY SYMBOLS
▽=0
△=0

GENERAL TOLERANCES (UNLESS SPECIFIED)

	mm	INCH
4 PLACES	± ---	± ---
3 PLACES	± ---	± .006
2 PLACES	± 0.15	± .010
1 PLACE	± 0.25	± ---

ANGULAR ± .5 °

DRAFT WHERE APPLICABLE
MUST REMAIN WITHIN DIMENSIONS

DIMENSION STYLE
MM/IN

DRAWN BY DATE
TMARTIN 2005/05/31

CHECKED BY DATE
FCARABETTA 2005/05/31

APPROVED BY DATE
KNOLLER 2005/05/31

MATERIAL NO.

SIZE
A3

SCALE 4:1

DESIGN UNITS METRIC

THIRD ANGLE PROJECTION

TITLE
BOTTOM ENTRY LOW PROFILE
MODULAR JACK
(THROUGH HOLE VERSION)

MOLEX INCORPORATED

DOCUMENT NO. SD-95502-001

SHEET NO. 1 OF 1

THIS DRAWING CONTAINS INFORMATION THAT IS PROPRIETARY TO MOLEX INCORPORATED AND SHOULD NOT BE USED WITHOUT WRITTEN PERMISSION